

Thermal Damage of Intake Valves in ICE with Variable Timing

S. A. Dmitriev* and A. E. Khrulev

Aerospace Institute, National Aviation University
Prospekt Kosmonavta Komarova, 1, Kyiv, 03058, Ukraine

*Email: sad@nau.edu.ua

ABSTRACT

The article provides the study on causes of damage to ICE intake valves, in the course of which the intake valve heads have been overheated and deformed as a result of material creep. On the example of the failure detected in the analysed engine, it has been established that the traditionally known reasons such as the combustion process failure cannot cause the damage described. For the purpose of determining the real causes of damage to the intake valves the authors simulated the thermal state of the intake valve in the heating-cooling conditions with the impact of gas in the cylinder and the impact of air in the intake pipe as well as the contact heat exchange with the seat with regard to thermal conductivity along the stem. The calculations have shown that with the increase of rotation frequency the failure of the control system that causes the engine to run at high rotation frequencies with a small intake valve lift leads to the temperature increase higher than it is recommended for the materials used, which causes the described overheating. Based on the conducted research the authors have developed recommendations for improving the reliability of the intake valves performance in the ICEs with variable valve timing.

Keywords: Internal combustion engine, intake valve, damage, failure, overheating, heat transfer, simulation, calculation method.

INTRODUCTION

The study practice of the internal combustion engine failures has long proven that valve damage in the gas distribution mechanism is a rather common phenomenon that occurs in engine operation. This kind of damage happens mostly due to the disruption in the thermal state of the valve which may be caused by various defects, service wear and/or mechanical impact.

It should be pointed out that in more than a hundred years of ICE production and operation valve damages have been studied rather thoroughly. Known technical literature on ICE failures, including technical reference handbooks on failures of the components produced by global manufacturers of engine spare parts [1,2], describe a large number of possible causes of valve damage. The most common signs of valve damages are wear (including pitting) on the face of the valve head, cracks, breakouts and burn-through of the valve head; wear, scuffing on the valve stem; deformation of the valve stem, damage (wear, cracks, and dents) of valve keeper grooves and valve stem end; mechanical destruction of valve stem in different sections. All these signs may point to various causes of damage, including:

- i. thermal overload due to leak integrity failure of the seat and valve or combustion failures which cause overheating, melting and valve head burn-through;

- ii. mechanical overload due to wear, excessive clearance in the driving or assembly errors, which can cause cracking, breakouts on the head and/or destruction of the valve;
- iii. abrasive wear of the work face of the seat or the stem due to poor air or oil filtration;
- iv. scuffing and jamming of the stem in the valve guide caused by manufacturing errors or excessive carbon formation on the stem that result in deformation or destruction;
- v. various types of corrosion including hot and fretting corrosion as well as face seat erosion that cause leak integrity failure of the valve seat as well as it is overheating;
- vi. other causes, connected to manufacturing or service repair errors, including axis misalignment of the seat and the guide caused by poor machining.

The experience in analysing engine failure causes of a large number of various engines [1,2] demonstrates that out of all the abovementioned valve damage causes the most common are the ones that cause thermal damage to valve heads. However, even the most thorough analysis of the signs of thermal damage to the valve as well as its causes discovers two particular facts that might appear odd at first glance: thermal damage of the valves is most often described without it being specified which valves – intake or exhaust ones – are being referred to; moreover, even the illustrations of such damage normally show exhaust valves; also, the description of thermal damage of the valves usually do not point out and/or do not mention intake valves at all, i.e. the type of damage typical of each valve type is not specified.

This might lead to believe that the intake valves can be expected to sustain thermal damage just as serious as the exhaust ones. However, as practice shows, the damaging of the intake valves caused by thermal overload is extremely rare unlike that of the exhaust valves. Moreover, some kinds of damage typical of the exhaust valves hardly ever happen to the intake valves.

Nevertheless, references to possible thermal damage of the intake valves can still be found in some sources. For example, in one of the reference books on engine components damage profiles, a well-known valve manufacturer appears to demonstrate the intake valve head deformed by overheating (in the typical shape of a “tulip” [2]). However, the illustration caption does not contain any indication of the valve type, the actual cause of the phenomenon or any other particularities apart from the general listing of thermal overload causes referred to the valves of all types. No comments are given in the documentation of other manufacturers either.

On the other hand, the study of the ICE cylinder head thermal state is very often conducted for the purpose of determining, among other things, valve temperatures. But even then, as it appears from numerous publications on the subject [3–8], the attention of the researchers is mainly given to the exhaust valves as the more critical engine components in terms of temperature.

This has an obvious explanation: intake valves, unlike exhaust valves, have a much lower running temperature, which is related to them being actively cooled by the cold air that comes from the intake system into the cylinder. For this reason, thermal damage to intake valves is relatively rare. The study of ICE failure causes, nevertheless, demonstrates that overheating of the intake valves as a result of thermal overload cannot be fully eliminated. However, since the intake valves run in conditions different from those of the exhaust valves, the damage process, as well as its causes, can differ from those of the exhaust valves. That would mean that the direct application of what is known

about the exhaust valves to the intake valves might give the wrong reason for their damage. Therefore, the objective of the present work is to analyse thermal damage of the intake valves, specify the causes and indications of such damage as well as add new information to the available data on ICE valve damage insofar as it relates to in-take valves.

EXPERIMENTAL DATA

Despite the absence of data in reference books, it turned out possible to practically determine the type of valve damage specified in them. The case in question was registered while studying the failure causes of a highly powered gasoline naturally aspirated engine V-6 with the capacity of 3.2L, direct fuel injection, and variable valve timing [9]. The engine failed just after a few hours of work at the very beginning of its operation due to the compression loss in several cylinders, with the failure being in some way related to the triggering of the warning signal in the valve timing mechanism, when it did not shift to greater intake phases in the cylinders at the increased rotation speed.

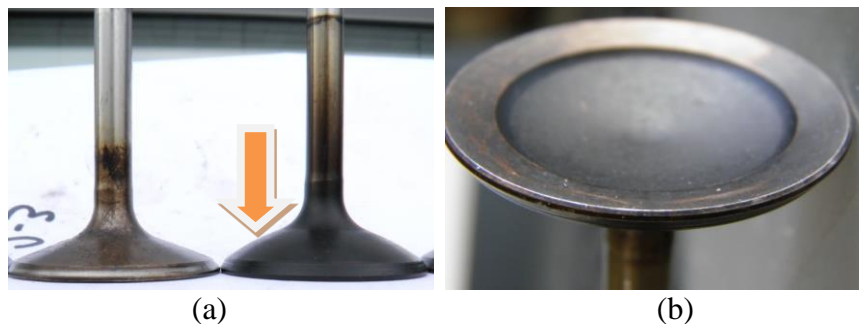

Figure 1. Head deformation of one of the intake valves (a) in the “tulip” shape of a “tulip” with the adjacent intake valve in the same cylinder having taken no damage (b), has no distinct explanation in the common list of causes of thermal overload of the valves including the combustion process failure.

The study of the failure cause has determined that in some cylinders the valve head of one of the two intake valves assumed the above-mentioned deformed shape of a “tulip” with clear traces of overheating (Figure 1). Meanwhile, the intake valves seated next to the damaged ones in the same cylinders appeared to have no signs of damage whatsoever. Neither the exhaust valves nor their seats had any signs of damage.

The known signs of failure worth mentioning also include various deformation stages of the intake valve head in different chambers (Figure 2), which clearly demonstrate that the deformation of the valve head first leads to the angle change of the valve face thus making it unfit to the face seat angle. This causes a drastic reduction in the width of the contact line between the face of the valve and the seat as well as result in its shift to the inner edge of the face.

Even insignificant deformation of the valve head leads the narrow width of the face contact line along the inner edge of the seat to cause excessive contact pressures and abnormally rapid wear of the valve face thus resulting in the forming of a typical narrow and deep groove on it (Figure 2). In what follows, the factual extension of the valve due to head deformation and valve face wear leads to clearance maladjustment in the valve driving and loss of contact between the valve and the seat, due to which the overheating of the valve head, judging by its colour in Figure 1, reaches its peak.



Figure 2. Valve head deformation causes its shift to the inner edge and a substantial reduction in the width of the contact line with the seat (a), which then leads to severe wear of the valve face and full loss of contact with the seat (b).

A corresponding situation can also be observed in the combustion chambers (Figure 3): the intake valve seats with the normal face are located next to the seats that have traces of contact with the valve along the inner edge of the seat. These can also have no trace of contact at all, which occurs when the valve is excessively stretched due to deformation of its head and the wear of the face.



Figure 3. Traces of abnormal contact of the intake valve with the inner edge of the seat (left), which indicates valve head deformation.

As it appears impossible to consider some sort of a combustion failure as an explanation for the selectivity of the overall impact of hot gases on only one of the intake valves with the remaining three having no such impact, it seems necessary to conduct a study of thermal processes in the cylinder head and to find the correlation between the temperature of the intake valves and the engine run mode with the final objective is to determine the possible causes of such failures.

THEORETICAL JUSTIFICATION

To begin with, it is necessary to clarify how the design of the engine itself can affect the results. This is an important factor since the engine manufacturer used a cam variable timing mechanism (Figure 4) that provides not only a lift change but also a change in the intake valve opening duration.

Design Features of The Analysed Engine

The control system maintains the lift as well as the opening duration of one intake valve in the combustion chamber while at the same time lowering the lift and the opening duration of the other intake valve when the rotation frequency and the load decrease. For the purpose, via the pulse provided to the solenoid valves, the axial displacement of the

cam element on the camshaft is performed, which enables the second valve lifter to shift its work on the cam of another profile. At the same time, the system shifts the valve opening phase towards the advanced direction, and the exhaust phase towards the retarded direction.

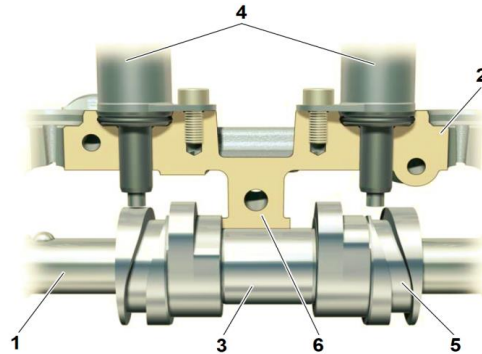

Figure 4. The scheme of the variable intake timing mechanism in the analysed engine: 1- camshaft, 2- frame, 3- sliding cam element mounted on the splines, 4- adjuster magnets, 5- groove for the axial displacement of the cam element, 6- axial bearing.

The variable gas timing is performed in stages as per the control program [10], in which both intake valves are opened simultaneously but can also be closed at various times depending on the engine run mode (Figure 5). According to the engine control program, the shift from smaller lift and opening duration of the intake valve to higher ones should be performed at the increased rotation frequency and load, however, the error code in the control system was registered exactly due to the absence of the said shift. This directly implies that the thermal failures of the intake valves in the analysed engine may originate from the point where the anomaly of their running mode takes place, that is, at a smaller lift of the intake valve at the increased rotation frequency and load.

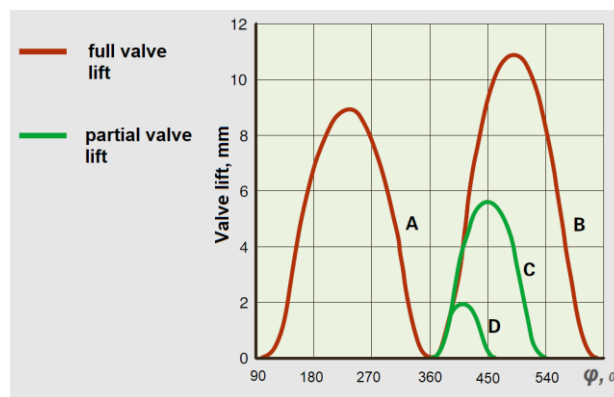

Figure 5. Variable valve timing control program of the analysed engine (full stroke line, partial stroke line, valve stroke in mm with respect to the crank angle in °).

Simulation of Thermodynamic Cycle in The Analysed Engine

The simulation was performed using the well-known Lotus Engine Simulation software [11]. The software calculates the instantaneous parameters of the thermodynamic cycle of the ICE (using average volume pressure and temperature in the cylinder) by the crank

angle. The gas flow in the intake and exhaust pipes is calculated as one-dimensional, which allows the dynamic occurrences in the pipes to be taken into account.

Since the objective was not to calculate the main integral parameters of the engine (power, torque and specific fuel consumption), but the temperatures of the elements, the simplified one-cylinder model was used. In order to perform the calculation of the cycle the actual dimensions of the cylinder (83×80 mm) and the valve mechanism (valve diameters being 30 and 26 mm) were set. The engine model (Figure 6) was built with two intake valves that in the general case have different control modes. The dimensions and the lengths of the pipes were also chosen close to the original sample.

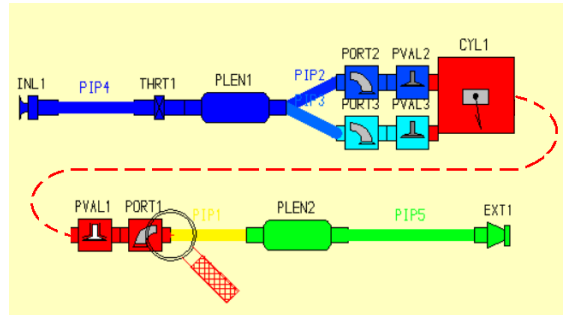

Figure 6. A one-cylinder geometrical model of the engine in the Lotus Engine Simulation software with the means of setting various lifts and phases of the intake valves.

The calculations of the cycle were performed for the rotation speed of 1000-6000 rpm with a step of 1000 rpm, full load, in three various intake valve timing modes (Figure 7) in accordance with the control scheme given by the engine manufacturer, specifically:

- i. both intake valves open up to the same max lift, h ;
- ii. one valve has a lowered lift (by 50%) and reduced opening duration (by 33%, Figure 7);
- iii. one valve has the minimum lift of 18%, its opening timing reduced by 66%.

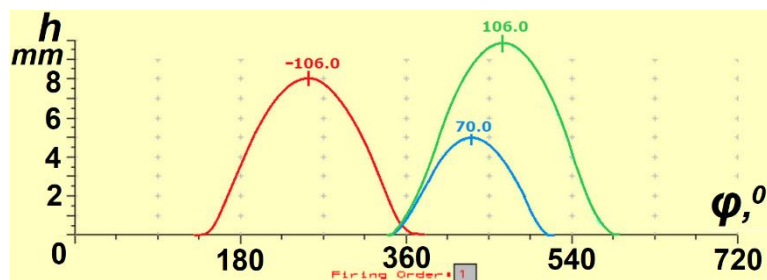

Figure 7. The valve timing for the calculation in Lotus Engine Simulation software: the mode with a lowered lift and reduced opening timing of one of the intake valves.

The overall shift of the intake timing to the advanced direction, same as the shift of the exhaust timing to the retarded direction, was not set, which has been done for the purpose of simplifying the calculations as well as due to the lack of precise data on the timing control set by the engine manufacturer.

The calculation of the cycle was conducted with regard to the heat exchange with the walls, which was achieved by setting the corresponding heat emission coefficients

(the software takes into account the heat exchange of the gas with the combustion chamber walls and the piston, as well as the heat reject to coolant).

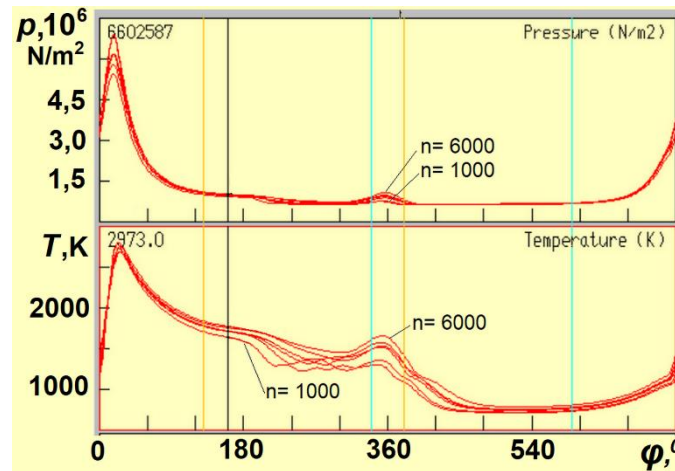
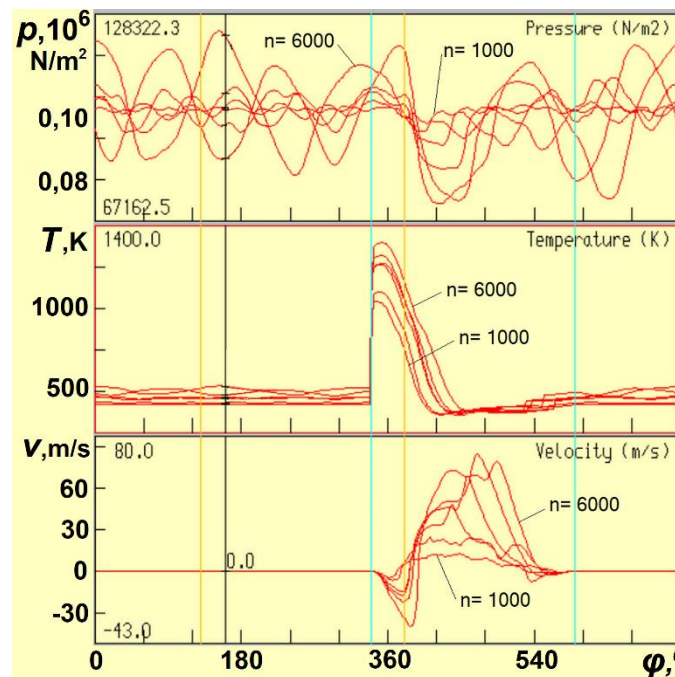
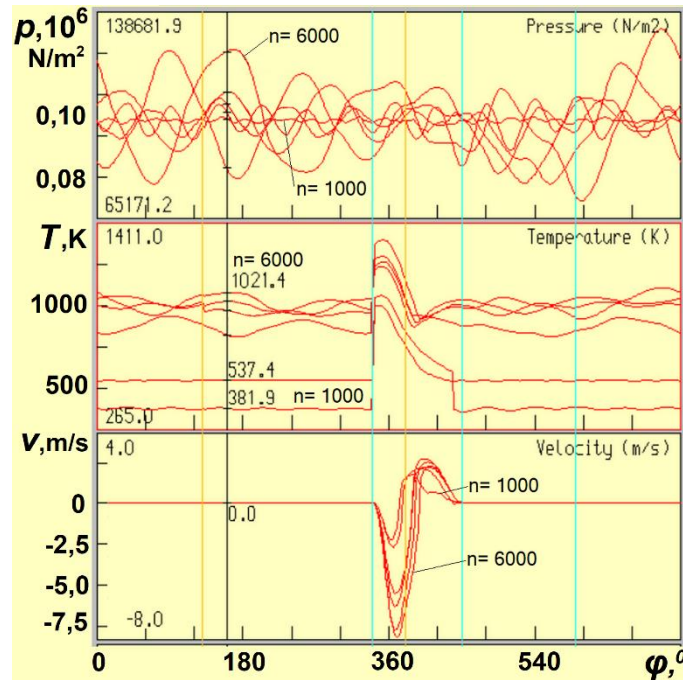

Figure 8. Pressure and temperature change of the gas in cylinder calculated by crank angle within the diapason of the rotation speed of 1000-6000 rpm for the event when both valves are opened simultaneously.

The calculation results are presented as dependency diagrams of the instantaneous parameters of air and gas in the characteristic sections, including the cylinder as well as all the pipes (Figure 8 and Figure 9(a)). In addition to that, all the instantaneous values of pressure, temperature and velocity were being saved as excel tables, the step being set by the crank angle equal to 2 degrees.



(a) both intake valves are opened simultaneously



(b) intake valve has a minimal opening

Figure 9. The change of instantaneous values of air pressure, temperature, and velocity in the section of the intake pipe before the intake valve at the various rotation speeds. In (b), the intake timing is short, and the back gas flow from the cylinder leads to the increase of air temperature in the intake pipe.

As per calculation results, the valve with a smaller lift and opening timing has turned out to have a substantially higher air temperature, which is related to the back gas flowing from the cylinder back into the intake pipe at the beginning of the valve opening (Figure 9(b)). It is clear that at higher air (gas) temperature in the pipe section the valve itself is also expected to have a higher temperature. However, determining the patterns of the intake valve temperature change is only possible if thermal calculation is performed.

Method for Calculating Intake Valve Temperature

For the purpose of determining the valve temperature the following simplifying assumptions have been established:

- i. the temperature distribution along the volume of the valve is not taken into account and it is considered that the valve head temperature T at each moment of time is the same along its whole volume;
- ii. the temperatures of the seat and the valve guide T_c are considered constant, equal and independent from the valve temperature and the conditions of heat exchange with it (which are set);
- iii. as far as the pipe is concerned, only the heat exchange of the valve head with the air and the thermal conductivity along the stem are taken into account; the heat exchange of the valve stem with the air in the pipe and the crankcase, as well as the gravitational impact on the heat exchange, are being ignored;
- iv. the characteristic velocity of the heat exchange process in the pipe is considered the air velocity in the pipe before the valve;

- v. the heat exchange impact of the intake valve head on the gas-dynamic processes is not taken into consideration.

Let us now look at the standard heating-cooling scheme of the valve (Figure 10), which represents the so-called heat boundary conditions for the cylinder head [4,8]. Out of the heat balance for the valve equation, the change of its inner energy dU over time $d\tau$ in the heating-cooling process is derived:

$$dU = (Q_r - Q_c - Q_k - Q_T) d\tau \quad (1)$$

where Q_r is the amount of heat that enters into the valve head from the gases in the combustion chamber, which have the temperature T_r ; Q_c , Q_k , Q_T are the amount of heat that goes to the seat, to the air that enters the valve and the valve guide as a result of the thermal conductivity along the valve stem, respectively.

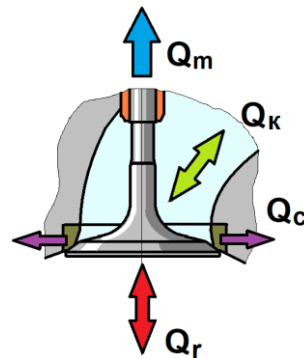

Figure 10. Thermal calculation model of the intake valve.

The change of the inner energy is proportional to the change of the valve head temperature T , its specific heat capacity C_p and mass m :

$$dU = C_p m dT,$$

where: $C_p = 550 \text{ J/kg K}$, $m = \rho V$ (ρ, V are the density and the volume of the valve head). The amount of heat that is supplied and removed from the valve in various processes is calculated in the following way:

$$Q_r = F \alpha_r (T_r - T), \quad Q_k = F \alpha_k (T - T_k), \\ Q_c = f_c \alpha_c (T - T_c), \quad Q_T = \frac{l}{\lambda} f (T - T_c).$$

where α_r, α_k are the coefficients of heat transfer from gas in the cylinder and from the air in the intake pipe to the valve head, α_c is the coefficient of the contact heat exchange of the valve with the seat, T_c is the temperature of the seat and the valve guide, F is the surface area of the valve head ($F = \pi D^2/4$), f_c is the contact area of the valve with the seat ($f_c = \pi D c$), where c is the width of the chamfer of the seat (it is assumed in the calculations that $c = 1,0 \text{ mm}$), f is the cross-sectional area of the valve stem ($f = \pi d^2/4$), l is the length of the stem from the valve head to the valve guide, λ is the thermal conductivity coefficient of the valve material.

Let us now consider in more detail the heat transfer coefficients contained in the formulas for calculating the amount of input and remove heat. The coefficient of heat transfer from the gas to the valve head can be found using the well-known Woschni's formula [3–6,8]:

$$\alpha_r = 128 (10 p)^{0,8} \omega^{0,8} / (T_r^{0,53} D_h^{0,2}) \quad (2)$$

where p , T_r are the gas pressure and temperature in the cylinder (MPa and K), D_h is the cylinder diameter in m, ω is the velocity coefficient proportional to the average piston speed $C_m = S n/30$, S is the piston stroke, n is the crankshaft rotation speed, rpm.

The velocity coefficient was taken to be $\omega = c_1 C_m + c_2 (p - p_k)$, where the values of the coefficients c_1 and c_2 were taken depending on the phase of the cycle [5], and p_k is the pressure in the intake manifold.

In order to determine the coefficient of heat transfer from the valve head to the air from the intake pipe, the following equation was used [5,6,12,13]:

$$Nu_k = 0,096 (Re)^{0,8} (Pr)^{0,43} \quad (3)$$

where $Re = v D/\nu$ is the Reynolds criterion determined at the open valve state by the velocity v of air in the pipe before the valve, with ν being the air kinematic viscosity coefficient.

At the closed valve state $v = 0$, but the heat exchange does not stop since it is affected by the oscillations occurring in the pipe. For this period of the cycle, as shown in [3], it is necessary that the criterion dependencies that describe the process of heat transfer should use the amplitude of the oscillatory velocity w , which is calculated out of the amplitude of pressure and sound velocity.

However, when simulating the airflow in the intake pipe, it is not necessary to calculate the amplitude of the oscillatory velocity, since the Lotus Engine Simulation program allows to find the desired amplitude directly when calculating the cycle. Thus, it turned out that the amplitude of air velocity oscillations at the valve head (at the distance of 30 mm) in different engine operating modes with given geometry (Figure 11) with a small valve lift depends mainly on the rotation speed and can be represented as $w = a n$, where a is the size factor [m x min / s].

After analysing the entire array of data on velocity in the given section of the intake pipe, obtained in different modes with small valve lifts, the value $a = 0.5 \times 10^{-3}$ was taken for further calculations.

The main attention in drawing up the procedure for calculating the temperature of the intake valve was paid to the formula for calculating the coefficient of contact heat exchange between the valve and the seat that depends on the pressing force of the valve. According to [3,4,6] the criteria dependence for this type of heat exchange is as follows:

$$Nu_c = (623 \lambda_{cp}/\lambda_{np} - 3,6) (p_f/\sigma_B)^{0,43} \quad (4)$$

where p_f is the contact pressure, $\lambda_{cp}/\lambda_{np}$ is the ratio of thermal conductivity of the medium that fills the contact spaces to the reduced thermal conductivity (approximately

$\lambda_{cp}/\lambda_{np} = 110 \times 10^{-4}$, σ_B is the strength limit of the seat material (for the calculations it is assumed that $\sigma_B = 500$ MPa).

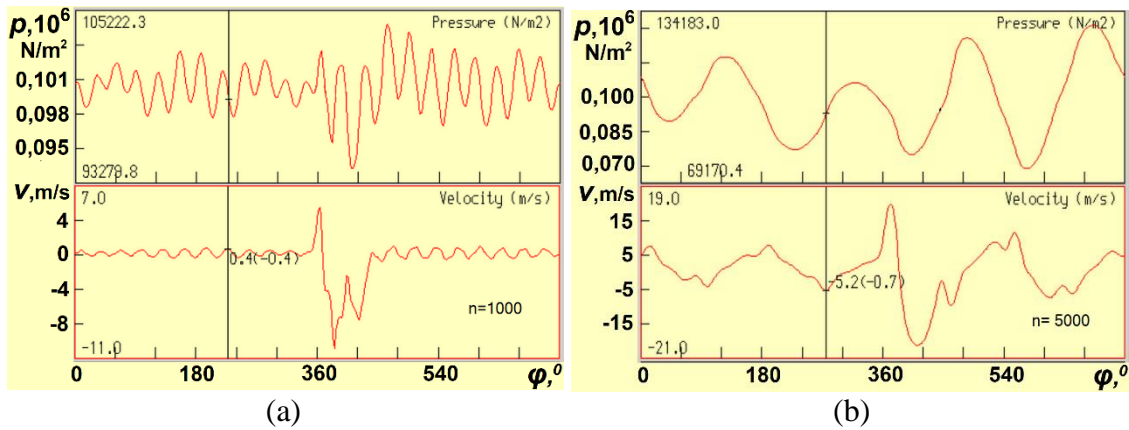

Figure 11. Oscillation of pressure and air velocity by the crank rotation angle in the intake pipe at a distance of 30 mm from the closed valve at (a) 1000 rpm and (b) 5000 rpm.

The contact pressure is determined by the following formula:

$$p_f = \cos \alpha_K / (\pi c D) \times [(\pi D^2 / 4) (p - p_K) + R_S] \quad (5)$$

where α_K is the angle of the valve chamfer ($\alpha_K = 45^\circ$); c, D are the width of the chamfer and the diameter of the valve head, R_S is the force of the valve spring (in calculations the constant value of $R_S = 50$ N is assumed), $(p - p_K)$ is the pressure drop across the valve.

The main difficulty in the practical application of Eq. (4) lies in determining the characteristic size H , which is the thickness of the sediment layer on the seat surface $\alpha_c = Nu \lambda / H$, where λ is the thermal conductivity coefficient of the sediment (carbon, resin).

Despite the availability of recommendations [1], it is not possible to determine the reliable value of H by any known method without experimental data on the engine of the type under study - at least, the results of such a calculation seem doubtful. However, for the qualitative picture, an attempt can be made to establish approximate dependencies.

Thus, in [3,4,6] it is indicated that the Nusselt criterion is proportional to the pressure contact with the seat with an exponent of 0,43. Taking into account that modern engines tend to have the minimum possible force of the spring, and also taking into account the proportionality of the contact pressure to the pressure of gases in the cylinder, the dependence for calculating the contact heat transfer coefficient in the first approximation can be represented as:

$$\alpha_c = A p^{0,43} .$$

Subsequently, heat exchange calculations with different values of the coefficient A , make it possible to find the dependence of the intake valve temperature on this coefficient. Further, with the approximate knowledge of the temperature of the valve in any characteristic mode, the value of the coefficient A for this mode and for all subsequent

calculations can be taken as constant. For example, it is known [14] that at maximum power mode, the temperature of the intake valve usually does not exceed 400-420⁰C (673-693K). Hence, after the preliminary calculation, the following values were chosen: 660K and the corresponding value $A = 6,0$ (Figure 13).

In order to convert Eq. (1) into a form convenient for calculations, it is necessary to take into account that time is related to crank rotation angle by the dependence $\varphi = \omega \tau$, whence:

$$d\tau = 30/\pi n \times d\varphi .$$

Then, Eq. (1) can be represented as:

$$\frac{dT}{d\varphi} = \frac{\pi n}{30C_p m} \left\{ \frac{\pi D^2}{4} [\alpha_r (T_r - T) - \alpha_k (T - T_k)] - \pi \left(c D \alpha_c - \frac{\lambda d^2}{4h} \right) (T - T_c) \right\} \quad (6)$$

This equation is easy to integrate numerically by any of the known methods. For this problem, given the approximate nature of the calculations, the simple Euler method is quite suitable. The essence of the method is that each subsequent value of the desired function differs from the previous one by the following value:

$$T = T + dT/d\varphi \times \Delta\varphi. \quad (7)$$

Equation (6) is solved by setting the initial temperature of the valve successively for each point of the cycle. Then, after having calculated the temperature change over the entire cycle with the given step (2^o crank rotation), the final temperature value is compared to the initial one. In case there is a difference between these temperature values, the next cycle is calculated until the difference in values disappears.

RESULTS AND DISCUSSION

Figure 12 shows the result of calculations of heat transfer coefficients for mode $n = 6000$ rpm with the maximum valve lift. The qualitative character of the change in the heat transfer coefficients indicates an increase in α_c with the increasing pressure in the cylinder, an increase in α_r with the increasing pressure and temperature in the cylinder, as well as an obvious increase in α_k with the increasing air velocity in the intake pipe. This is overall confirmed by the data from [3–5,15].

The calculations were then carried out for all the intake valve lifts and intake timing at different rotation speeds, the results are presented in Figure 13. The obtained results demonstrate that with an increase in rotation speed, a decrease in the valve lift and in the intake timing, the temperature of the intake valve increases. The observed nature of the temperature change is caused by the decreased air cooling of the valve which occurs, among other factors, as a result of the hot gas flow from the cylinder into the intake pipe in some of the modes according to Figure 9(b).

It should be noted that the revealed tendency for the intake valve temperature to rise is confirmed in the recommendation of the manufacturer of the engine under study:

the owner manual indicates that in case at an increased rotation speed a failure in the timing control system occurs that is related to the absence of shift to higher valve lift, it is necessary to limit the operating speed of the engine to 4000 rpm [10].

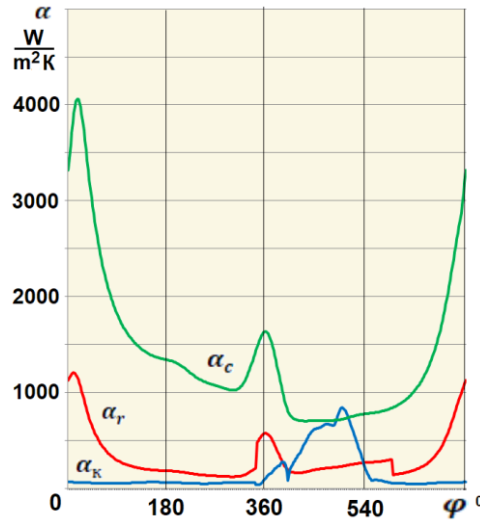

Figure 12. The calculated change in the instantaneous heat transfer coefficient over the cycle at n=6000 rpm with the full opening of the intake valve (head temperature is 660K).

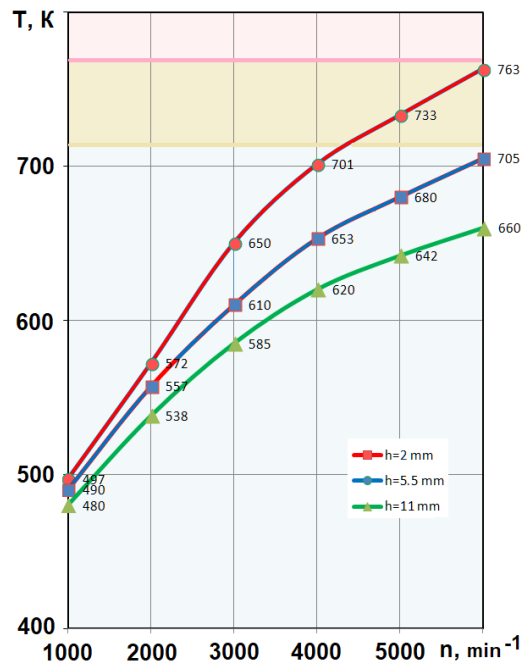

Figure13. The dependence of the temperature of the intake valve on its lift (and the opening duration) with increasing rotation speed.

According to the results of the calculation, the temperature of the intake valve with incomplete opening and the rotation speed of more than 4000 rpm exceeds 700K. Let us estimate this boundary value by comparing it with the known data on the properties of valve steels [16]. The most common valve steel used for manufacturing intake valves

for gasoline engines is the X45CrSi93 steel. Indeed, upon checking the composition of the valves of the engine under study it turned out that this particular steel was used (see the Table 1).

Table 1. Valve material analysis results.

Steel grade	Chemical composition (%)			
	C	Si	Mn	Cr
Test valve	0.39	3.1	-	9.1
X45CrSi93	0.40-0.50	2.7-3.3	< 0.80	8.0-10.0

The temperature properties of this type of steel are such (Table 2) that after being heated up to above 500°C (773K), the signs of creep begin to appear on it, and already at the temperature above 550°C its application becomes no longer possible. This explains the fact that the use of this type of steel is being limited exclusively to intake valves since in the process of engine operation they do not normally get heated above 450°C (723K).

Table 2. Properties of steel X45CrSi93 [16].

Parameters	Temperature (°C)			
	20	500	550	600
Temporary strength (MPa)	930	660	580	430
Yield stress (MPa)	670	455	420	370
Creep limit (MPa) at a strain of 1% for 10000 h	-	216	127	-

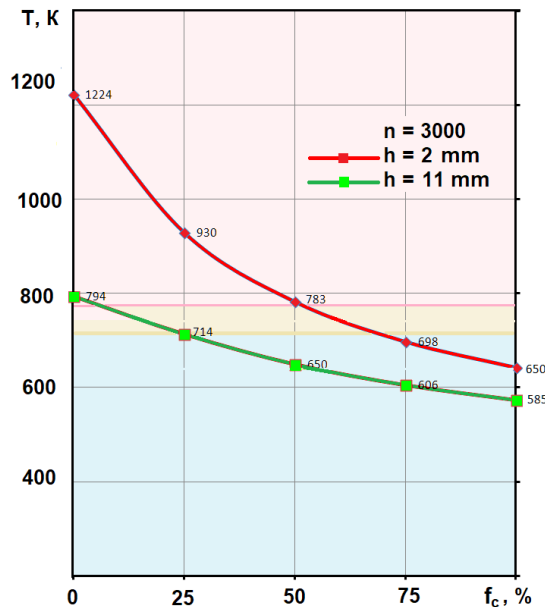

Figure 14. According to the simulation results, the intake valve with a minimum lift ($h=2$ mm) overheat even at a small loss of the contact area with the seat (specified by the relative contact area f_c).

Thus, the design temperature up to which the closed intake valve is heated at the rotation speed of more than 4000 rpm, can exceed the temperature range recommended

for the application of the X45CrSi93 valve steel. As it follows from the nature of the valve damage (Figure 2), even a slight deformation of its head leads to a significant reduction of the contact area of the valve with the seat. This process can be approximately modelled by setting a smaller chamfer width in the Eq. (5).

The calculation results in Figure 14 show that with the minimal intake valve lift, reducing the contact width by more than 2 times already leads to unacceptable heating of the valve head, which further leads to its deformation due to creep. It can be assumed that this is an avalanche-like process in the positive feedback mode - even a slight initial deformation of the valve head due to creep leads to a decrease in the contact area with the seat, an increase of temperature and even greater deformation.

CONCLUSION

According to the available experimental data, the “selective” thermal deformation of the intake valves heads due to the creep of the material under excessively high temperature is not related to the commonly known causes of such damage, including the combustion process disruptions. The study performed on a variable valve timing engine has shown that the cause of the creep of the intake valve material is the operation of the intake valve with lowered valve lift and opening timing while there is a failure in the control system when the intake valve opening at the increase of engine rotation speed (above 4000 rpm) and load is not secured. In this case, the process has a progressive pattern, in which a small thermal deformation of the valve head with a reduction in the contact area with the seat by 1.5-2 times leads to a further increase in the temperature of the head and to an even greater deformation.

Since the thermal deformation of the intake valve head in the case of this failure is caused by its more intense heating (above 700K), an effective way to prevent the engine failure is the application of a more reliable valve mechanism design as well as the intake valves made of more heat-resistant steels in said engines.

REFERENCES

- [1] Greuter E, Zima S. Engine failure analysis. internal combustion engine failures and their causes. Warrendale: SAE International; 2012.
- [2] Engine Components and Filters: Damage profiles, probable causes and prevention. Technical Information. MS3-1109, Farmington Hills: MAHLE Aftermarket Inc.; 2010.
- [3] Rosenblit GB. Heat transfer in diesel engines. Moscow: Publishing House Mashinostroenie; 1977, p. 216.
- [4] Chaynov ND, Migkov LL, Malastovsky NS. The method of calculating the temperature fields of the cylinder head with valves. Bulletin MGTU im. N.E. Bauman. Ser. "Engineering", 2012; 82-91.
- [5] Levterov AM, Levterova LI. Analysis of mathematical models of the mechanism of soot formation during the combustion of hydrocarbon fuels. News of NTU "KhPI". Ser. Mathematical modeling in tech and technology, 2013; 5(979): 130-141.
- [6] Onishchenko DO, Pankratov SA. Simulation of the thermal condition of the cylinder head and diesel valves. ISSN 0236-3941. Bulletin MGTU im. N.E. Bauman. Ser. "Engineering", 2013; 4: 94-108.

- [7] Plotnikov LV, Zhilkin BP. Gas dynamics and local heat transfer in the intake channel with different cross-sectional shape of a piston internal combustion engine of dimensions 8.2/7.1. *Polzunovsky vestnik*, 2010; 4/2:137-143
- [8] Wang CS, Berry GF. Heat transfer in internal combustion engines. In: *The American Society of Mechanical Engineers: Winter Annual Meeting Miami Beach, Florida, USA, 17-21 November, 1985.*
- [9] Raghuwanshi NKr. Failure analysis of internal combustion engine valves: a review. *International Journal of Innovative Research in Science, Engineering and Technology*, 2012; 1(2): 173-181.
- [10] Audi 2.8l and 3.2l FSI engines with Audi valvelift system. Self-study programme 411. Ingolstadt: AUDI AG; 2007.
- [11] Duleba B. Simulation of automotive engine in Lotus simulation tools. *Transfer inovacii*, 2014; 30: 48-52.
- [12] Heywood JB. *Internal combustion engine fundamentals*. McGraw-Hill series in mechanical engineering. New-York: McGraw-Hill Inc.; 1988.
- [13] Draganov BH, Kruglov MG, Obukhov VS. Designing of the intake and exhaust pipes of internal combustion engines. Kyiv: Vishcha shkola; 1987:175.
- [14] Vyrubov DN, Ivaschenko NA, Ivin VI et al. In: Orlin AS, Kruglov MG, editors. *Internal combustion engines: Theory of piston and combined engines*. Moscow: Publishing House Mashinostroenie; 1983, p. 372.
- [15] Kabanov AN. Choosing of the calculation method for heat transfer process in gas engine with spark ignition. *Automotive Transport*, 2012; 30: 96-102.
- [16] ISO 683-15:1992. Heat-treatable steels, alloy steels and free-cutting steels. Part 15: Valve steels for internal combustion engines. ISO/TC 17/SC 4, 1992.